

PRODUCT SHEET

Description:

Twin Wheel Castor $\varnothing 50$ mm, Black, W/Brake, Stem M8 x 15mm, MH: 60mm

Item number:

08.04.110-1

Units	Box	Carton	HS Code	Barcode
Pcs.	4	300	8302200090	
				5704866005654

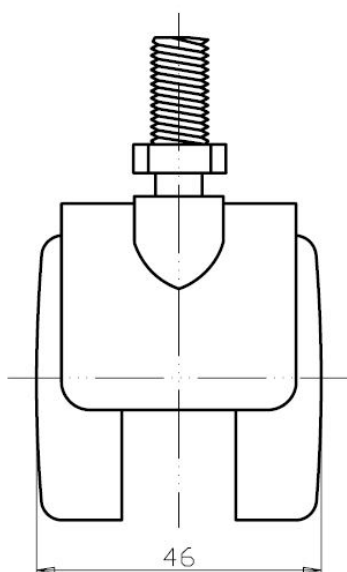
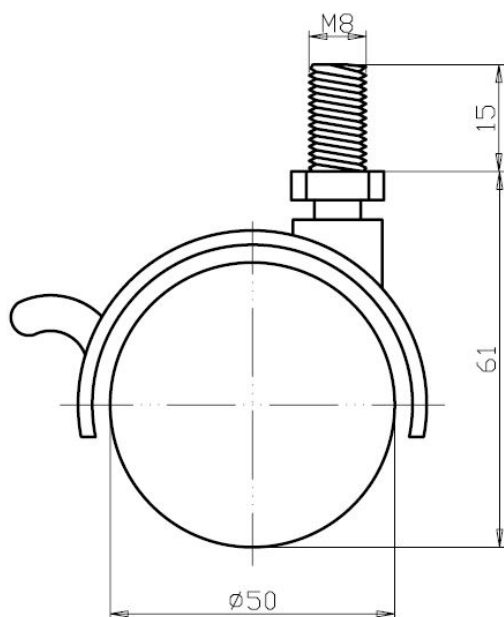

SISO A/S

Mileparken 11
DK-2740 Skovlunde
Denmark
VAT: DK 24786013

Phone +45 45 830 900

www.siso.dk
siso@siso.dk

Danske Bank
Nytorv Branch
Copenhagen
SWIFT: DABADKKK

Account no.
4180 3112 112936
IBAN Account
DK7230003112112936